

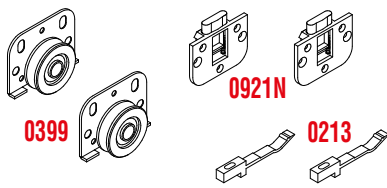

KIT 0921-399 NN - MAX 30 KG



Legenda KIT / Kit Legend

0399	Carrello inferiore <i>Lower truck</i>
0213	Fermo superiore per profilo Art. 0211 <i>Upper stopper for profile Art. 0211</i>
0921N	Catenacciolo superiore <i>Upper security chain</i>

Legenda altri componenti *Legend other items*

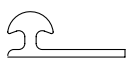
0211		Profilo plastica superiore <i>Upper plastic profile</i>
0380		Profilo alluminio inferiore <i>Lower aluminium profile</i>
0300		Profilo alluminio inferiore <i>Lower aluminium profile</i>

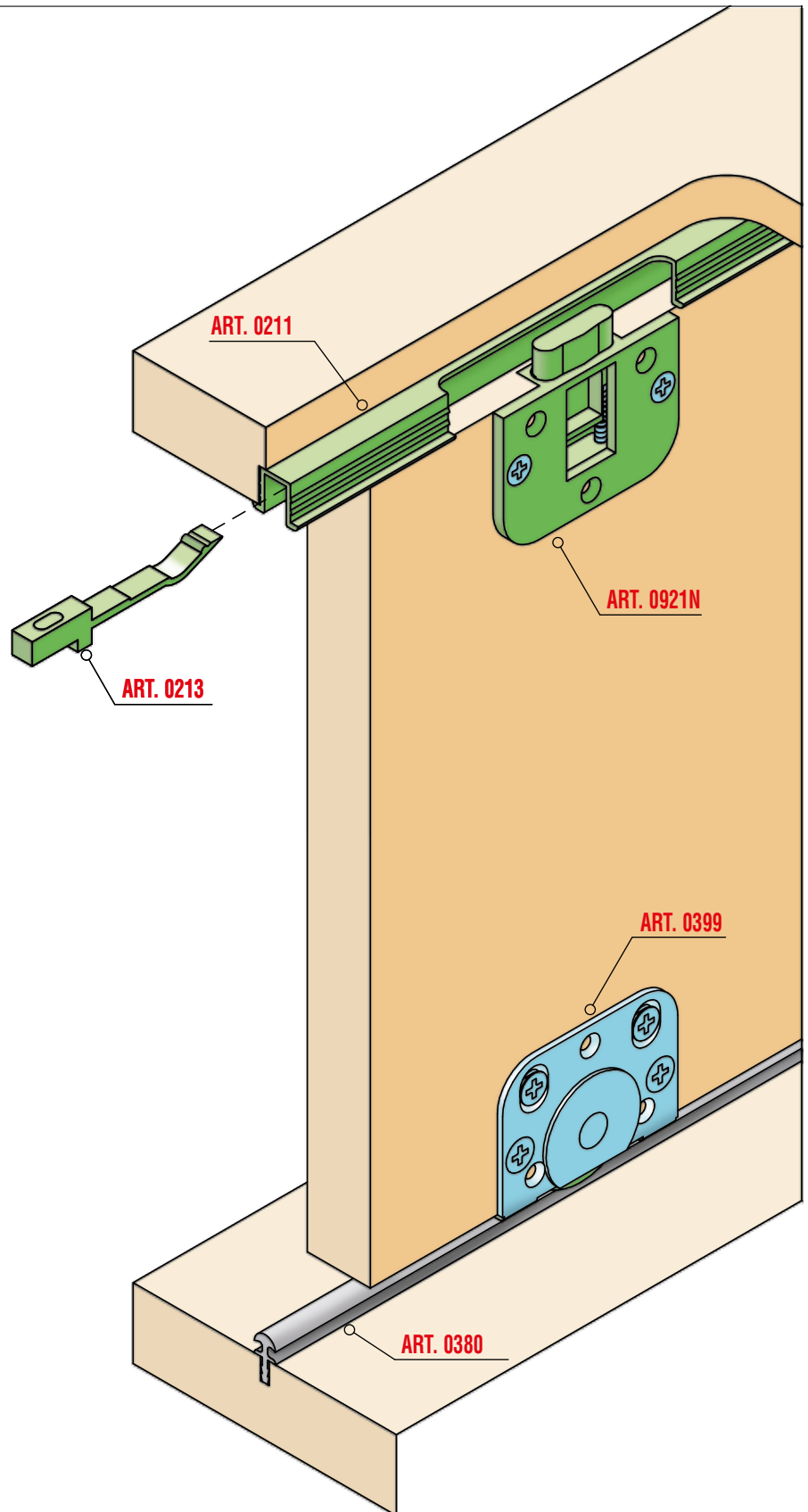



Sezione verticale / Vertical section

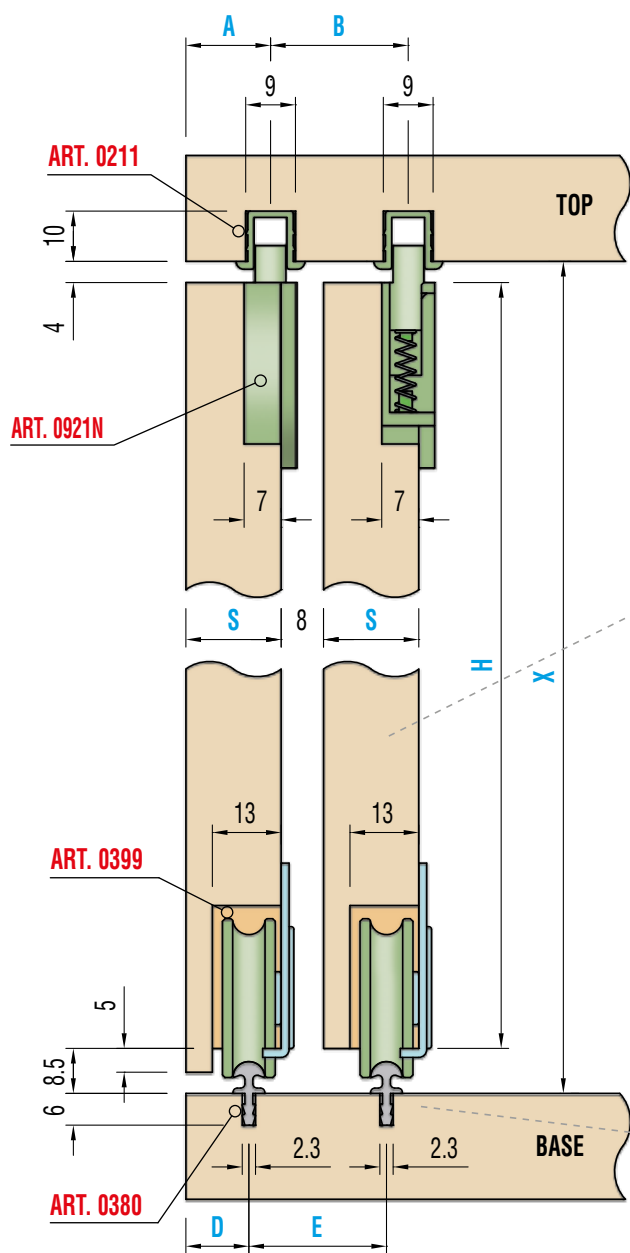

Peso massimo anta Kg. 30
Maximum door weight Kg 30

A =	S* -2
B =	S* +8
C =	S* -6
D =	S* +8
H =	X -12,5

S* (spessore / thickness)
min.16

**Variante
Special version**

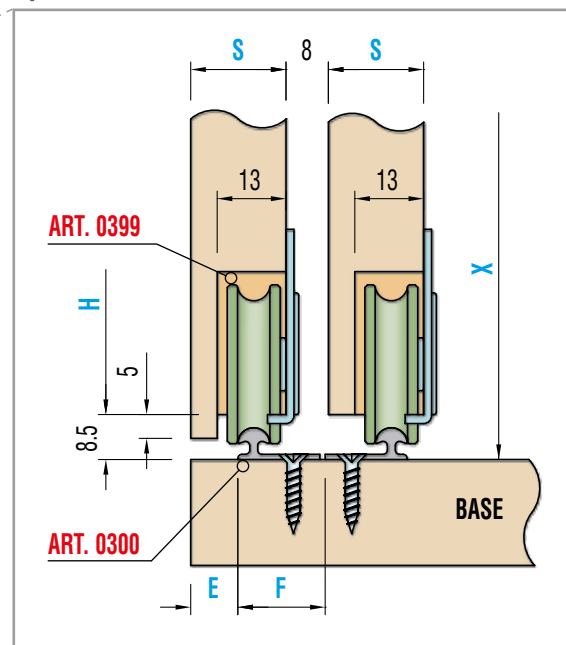

E =	S* -9
F =	S* -1,5
H =	X -12,5

Schema Foratura ante / Doors drilling

